



# SEISMIC ISOLATION BASE ISOLATORS



Design according to

# BS EN 15129



<b>1</b>	<b>Base Isolation</b>	
	1.1 Importance of Basic Isolation	1
	1.2 Concept of Basic Isolation	1
<b>2</b>	<b>Types of Seismic Bearing</b>	
	2.1 High Damping Rubber Bearing (HDRB)	2
	2.2 Lead Rubber Bearing (LRB)	2
<b>3</b>	<b>Characterization</b>	
	3.0 Characterization of Seismic (Elastomeric) Rubber Bearings	3
	3.1 High Damping Rubber Bearing (HDRB) characterization	4
	3.2 Lead Rubber Bearing (LRB) characterization	5
<b>4</b>	<b>Design Features</b>	
	4.0 Design Features	6
	4.1 Basic of Design according to BS EN 15129:2009	7
<b>5</b>	<b>Schedule</b>	
	5.0 Typical Bearing Schedule	10
<b>6</b>	<b>Tables</b>	
	6.1 High Damping Rubber Bearing	11
	6.2 Lead Rubber Bearing	20
<b>7</b>	<b>Material Specification</b>	
	7.0 Mechanical and physical properties of high damping elastomers	26
<b>8</b>	<b>Restraint &amp; Anchorage</b>	
	8.0 Restraint & Anchorage Design	27
<b>9</b>	<b>Testing Method</b>	
	9.0 Testing Method accordance to EN15129	28
<b>10</b>	<b>Installation</b>	
	10.1 Installation	29
	10.2 Connection Methods	33
<b>11</b>	<b>Project Reference</b>	
	11.1 High Damping Rubber Bearing	34
	11.2 Lead Rubber Bearing	37

# Company Overview

## DOSHIN RUBBER PRODUCTS (M) SDN BHD

Doshin Rubber is one of the leading rubber manufacturers in specialized rubber products for civil engineering applications and is also a subsidiary of Kossan group of companies, a public-listed company in the stock exchange of Malaysia (Bursa Malaysia). Located in Klang, Malaysia, Doshin Rubber designs, manufactures and tests a wide range of rubber products such as seismic bearing, structural bearing, marine dock fender, and expansion joint. Over 40 years, Doshin Rubber has branded ourselves as committed manufacturer through accreditations of our production and testing capability to international standards such as ISO 9001 and ISO 17025. Doshin Rubber has obtained the CE Marking certification for seismic isolation products such as the Lead Rubber Bearing (LRB), High Damping Rubber Bearing (HDRB) and Friction Pendulum Bearing which means that the manufacturing and testing procedures are in full conformity to European Union (EU) Standards. Our full in-house testing facilities have the capacity to test seismic bearing up to 2000 mm in diameter or maximum shear movement of + 1200 mm. We have one of the world's largest testing facilities to achieve 50 000 kN of compression force and 4 000 kN shear for combined compression and shear test of seismic isolators. We have experienced teams working together to provide unique solutions tailored to suit the needs of different project requirements respectively.





# 1.0 Base Isolation

## 1.1 Importance of Base Isolation

Base isolation offers important advantages over a conventional protection method because it reduces the earthquake forces transmitted into a structure. Thus, it protects not only the structure itself but also the contents and secondary structural features. This is particularly important for buildings with important contents such as hospitals or emergency facilities that need to maintain full serviceability after an earthquake.

Base isolation has now become an established and accepted technology all over the world. The technique is applicable to bridges and industrial structures, such as LNG tanks, in addition to buildings. While it is usually cheaper to apply base isolation in new structure, it is also plausible to use base isolator for seismic retrofitting of existing structure.

The capability to protect the contents is a major advantage for buildings such as hospitals and emergency centres where maintenance of functions during and after an earthquake is necessary, and in cases such as museums and advanced technology factories where the value of the contents is high. In addition, it does not disrupt the architectural layout of the superstructure which makes base isolation an ideal choice for seismic retrofitting of historical monuments.

Base isolation concept typically calls for separation of whole of the superstructure from the lower part of the structure by an interface that is soft and flexible in the horizontal direction. Generally, the interface is placed between the foundation or basement and the ground floor as the term 'base isolation' suggested.

In a base isolated building, the structure is isolated from its foundations so as to minimize the effect of ground motion on the superstructure and, thereby, reduce its force and deflection response. The difference in how conventional structures and base isolated structures respond to earthquakes is illustrated in the figure below.

Savings in the superstructure can be expected through a reduction of forces due to the isolation system. This reduction of forces allows for greater flexibility in space planning and reduced footprint of structural elements. As a whole, it also reduces the lateral load resisting elements of the foundations.

## 1.2 Concept of Base Isolation

Base isolation is achieved by mounting the structure on a system of supports which gives relatively lower stiffness in horizontal direction. The natural period of the structure on the isolation system is typically two seconds. This period is chosen to be long compared with both the dominant period of the earthquake ground shaking and the period of the superstructure in the fixed-base conditions.

The figure below shows that the period lengthening greatly reduces the acceleration response compared with that of a typical conventional structure. It also shows that the response to input excitations at the isolation period, and the amplitude of the horizontal movement of the structure. It is important to realise that despite the need for some damping, the isolators are not principally acting to absorb the energy of the earthquake, but are providing an interface that decouples the building from ground motion thus reducing the transmission of forces onto the structure.

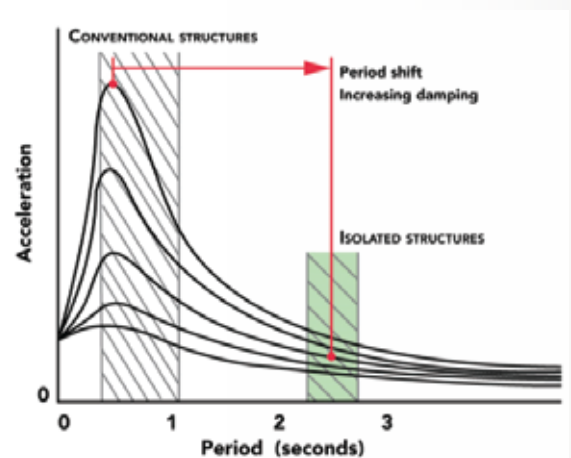

Therefore, during an earthquake, the structure moves virtually as a rigid body on the isolators. The deformation is concentrated at the isolation interface. Unlike the superstructure, the isolation system can accommodate large deformations without significant damage.



# 2.0 Types of Seismic Bearing

Two types of elastomeric based seismic bearings are contained within this catalogue; namely:

## 2.1 High Damping Rubber Bearing (HDRB)

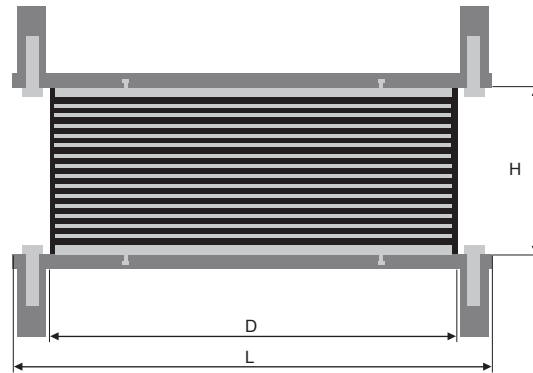

- $D$  = Diameter
- $d_{max}$  = Maximum horizontal displacement ( including seismic actions)
- $F_{z,d}$  = Maximum vertical load ( non- seismic) at ULS with zero horizontal displacement
- $N_{Ed,max}$  = Maximum vertical load including seismic load combinations
- $K_v$  = vertical stiffness
- $K_h$  = effective horizontal stiffness at = 1
- $T_r$  = Total height of rubber

## 2.2 Lead Rubber Bearing (LRB)

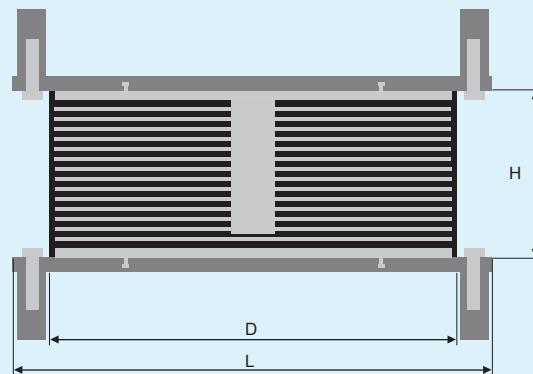
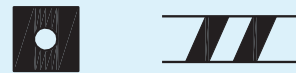

- $D$  = Diameter
- $d_{max}$  = Maximum horizontal displacement ( including seismic actions)
- $F_{z,d}$  = Maximum vertical load ( non- seismic) at ULS with zero horizontal displacement
- $N_{Ed,max}$  = Maximum vertical load including seismic load combinations
- $K_h$  = effective horizontal stiffness at = 1
- $T_r$  = Total height of rubber

Both HDRB and LRB are rubber-based seismic bearing, made of layers of steel plates and rubber layers. The major difference between the two is that in HDRB, the hysteresis damping solely depends on the formulation of the rubber compound, i.e. the mechanism of rubber in energy dissipation. In LRB, the damping is provided when the lead core yields.

# 3.0 CHARACTERIZATION OF SEISMIC (ELASTOMERIC) RUBBER BEARINGS

For a correct dimensioning of elastomeric seismic bearings regardless of whether they are High Damping Rubber Bearing (HDRB) or Lead Rubber Bearing (LRB), in view of an intervention of base isolation of a structure, we need to consider properly the following typical properties: horizontal stiffness [kN/mm], damping [%], horizontal displacement capacity [mm], vertical stiffness [kN/mm] and vertical load capacity [kN].

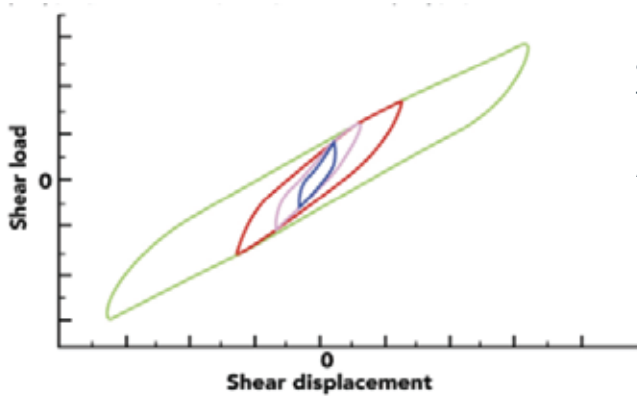

The horizontal force-deflection loops for a typical bearing over a range of displacements are shown in the figure on the left; the stiffness is seen to be higher at small deflections. The area of the loops indicates the level of damping intrinsic to the bearing.

A bearing can be designed to have the characteristics desired by adjusting:

- Shear modulus of the rubber compound;
- Plan area;
- Thickness and number of rubber layers; and
- Thickness of steel reinforcing plates.

Generally, an equivalent linear model is used to represent the stiffness and damping of the isolator.

## Schematic force-displacement loop for LRB

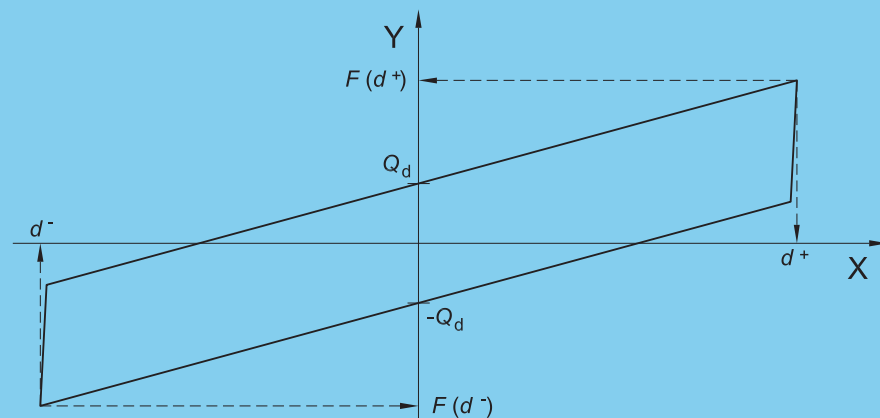

$$K_2 = \frac{F(d^+) - F(d^+/2)}{d^+} - \frac{F(d^-/2) - F(d^-)}{d^-}$$

Key  
 X Displacement  
 Y Force

## 3.1 High Damping Rubber Bearing (HDRB)

Base isolation of a structure requires an interface with the following characteristics between the foundation and the superstructure:

- Low horizontal stiffness at design displacement;
- High vertical stiffness;
- Capability to support the gravity load of structure over long term;
- Capacity to accommodate large horizontal displacements during earthquakes and at same time support vertical load including seismic loads;
- Moderate level of damping;
- Capability to re-centre structure after the earthquake;
- Stable stiffness and damping properties over long term;
- High initial horizontal stiffness to provide wind restraint;
- Ability to function again after the design earthquake.

High Damping Rubber Bearing (HDRB) is a simple, cost-effective and maintenance-free device that provides the isolation interface. They can be designed to withstand the design earthquakes without significant damage.

The HDRB consists of alternative layers of rubber and steel. The steel plates can greatly increase the vertical stiffness of the bearing. The plates enable the bearing to support the vertical load even under a large shear displacement. A strong bond between the rubber and steel is critically important to the correct functioning of the bearing. The rubber (usually a compound based on natural rubber) is specially formulated to give the performance especially the damping required.

The use of high damping rubber avoids the need for auxiliary dampers such as viscous or elasto-plastic steel dampers in the isolation system.

Doshin Rubber's HDRBs are steel laminated rubber bearings made on specially formulated high damping natural rubber compounds. The rubber compounds used for the production of Doshin Rubber's HDRBs are characterized by a dynamic shear modulus  $G$  variable from 0.6 to 1.1 MPa and an equivalent viscous damping coefficient (at shear strain,  $\gamma=1$ ) varying from 10 to 20%. The non-linear behavior of the compounds characterizes that at low shear strain the shear modulus is higher, allowing only slight movement due to forces such as wind. The steel lamination ensures a high compression stiffness to support the vertical load.

Three different rubber compounds are available as standard:

- Soft compound (S), with a low modulus ( $G=0.6$  MPa);
- Normal compound (N), with a medium modulus ( $G=0.9$  MPa);
- Hard compound (H), with a high modulus ( $G=1.1$  MPa).

Despite having a rather comprehensive list of HDRB sizes, Doshin Rubber is able to develop alternative rubber compounds to satisfy different design requirements and can design seismic isolators to all the international standards.

The information provided is intended for preliminary calculations. We would be pleased to discuss with our clients on their application and it is highly possible to consider for any adjustments to the geometry and connection details of the bearings to suit the project requirements. For further information or additional remarks, kindly refer to our technical department.



## 3.2 Lead Rubber Bearing (LRB)

Lead Rubber Bearing (LRB) is used when the energy dissipation requirement is higher. Although this is also achievable by HDRB, some structural designers preferred LRB due to the established analysis model that has been well accepted and adopted in structural analysis. Similar to the HDRB, LRB also consists of alternative layers of rubber and steel. The steel plates can greatly increase the vertical stiffness of the bearing, which enables the bearing to support the vertical load even under large shear displacement. A strong bond between the rubber and steel is critically important to the correct functioning of the isolator. In LRB, the hysteresis damping is greatly influenced by the high purity lead core rather than the rubber.

Doshin Rubber's LRBs are steel laminated rubber bearings made on soft rubber compound, usually with dynamic shear modulus  $G$  of 0.4 MPa. Please be noted that, the classification of dynamic shear modulus of S, N and H compound for LRB could be slightly different from the HDRB's.

The LRB contained in this catalog is based on rubber compound of 0.4 MPa, which is typically used. However, Doshin Rubber is able to develop alternative design for different project requirements to satisfy different design standards or site requirement. Similar to the HDRB, we would be pleased to discuss with our clients on their application and it is highly possible to consider for any adjustments which is impossible to list them all in the catalog for selection.

# LEAD RUBBER BEARING

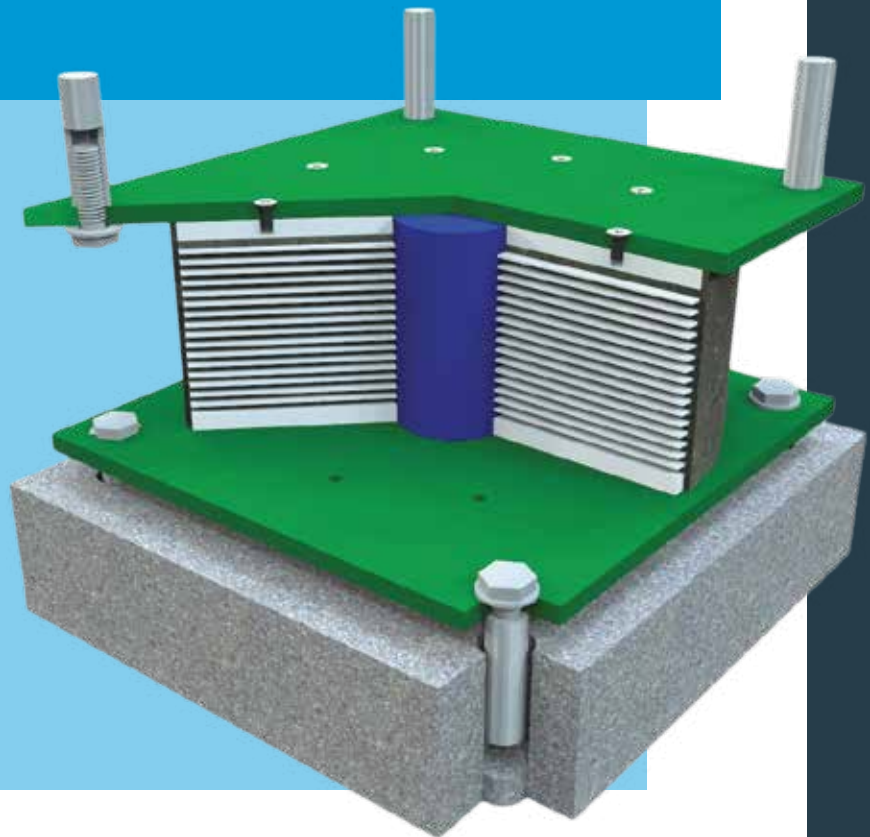



## 4.0 DESIGN FEATURES

This catalogue serves for preliminary seismic bearing selection purpose. All products description and design values contained herein are accurate to our best knowledge under laboratory environment and design theory. Please contact our technical department should further information is required.

Design of the seismic bearing are shown in this section. Main steps and equations are shown. For further information or additional remarks, kindly refer to our technical department. Structural engineer has to provide essential data for bearing manufacturer to come up with the right bearing design. Determination of such data by the bearing manufacturer is not the scope of bearing manufacturer. Important design input to be made available to our technical department in order to optimize the seismic bearing design output is contained at the end of this catalogue.

## 4.1 BASIC OF DESIGN according to BS EN 15129 : 2009

### 4.1.1 Design shear strain due to compression by vertical loads

The design local maximum shear strain due to the compressive strain  $\epsilon_{c,E}$ , corresponding to the maximum vertical load,  $N_{Ed,max}$ , is given by:

$$\epsilon_{c,E} = \frac{6 S N_{Ed,max}}{A_r E'_c}$$

$S$ , the shape factor of the rubber layers, with internal reinforcing plates of diameter  $D'$  and rubber layer thickness  $t$  :

$$S = \frac{D'}{4t_r}$$

$A_r$  is the reduced effective plan area due to non-seismic actions only (e.g. thermally induced actions).  $E'_c$  for rectangular devices, circular devices and annular devices with plugged hole is:

$$E'_c = 3G (1 + 2S^2)$$

### 4.1.2 Design shear strain due to earthquake-imposed horizontal displacement

The design shear strain,  $\epsilon_{q,E}$ , due to the earthquake-imposed design displacement  $d_{bd}$ , is given by:

$$\epsilon_{q,E} = \frac{d_{bd}}{T_q}$$

where  $T_q$  is the total thickness of the elastomer active during shear.

### 4.1.3 Buckling load at zero lateral seismic displacement

The buckling load for devices with a shape factor,  $S > 5$  is given by the expression:

$$P_{cr} = \frac{\lambda G A_r a' S}{T_q}$$

For circular devices  $a'$  is the effective diameter  $D'$  of the device. For bearings with holes, plugged or unplugged,  $A_r$  shall exclude the area of the holes.

### 4.1.4 Design Shear Strain

The shear strain,  $\epsilon_{q,max}$ , due to the maximum horizontal displacement,  $d_{bd}$ , shall be less than 2,5 ,

$$\epsilon_{q,max} \leq 2,5$$



#### 4.1.5 Maximum Total Design Shear Strain

The maximum total design shear strain  $\mathcal{E}_{t,d}$  is given by the expression:

$$\mathcal{E}_{t,d} = K_L ( \mathcal{E}_{c,E} + \mathcal{E}_{q,max} + \mathcal{E}_{\alpha,d} )$$

#### 4.1.6 Buckling stability under seismic actions

$$N_{Ed,max} < P_{cr} / 2$$

For  $\frac{P_{cr}}{2} > N_{Ed,max} \geq \frac{P_{cr}}{4}$ , the following condition shall be satisfied:

$$1 - \frac{2N_{Ed,max}}{P_{cr}} \geq 0,7\delta$$

and for  $N_{Ed,max} < \frac{P_{cr}}{4}$  the following condition shall be satisfied:

$$\delta \leq 0,7$$

$$\text{where } \delta = \frac{d_{Ed}}{a'}$$

#### 4.1.7 Roll-over stability under seismic actions

If recessed isolators or isolators with dowel connection are used by agreement of the Structural Engineer, the roll-over stability shall be checked using the following relation:

$$d_{Ed} \leq \frac{1}{\gamma_R} \frac{N_{Ed,min} \cdot a'}{(K_b T_b + N_{Ed,min})}$$

where

$N_{Ed,min}$  is the minimum vertical force at the design seismic situation;

$K_b$  is the horizontal shear stiffness measured at the largest test displacement;

$T_b$  is the total height of the device;

and  $\gamma_R$  is a partial factor, the recommended value of which is 1,5.

#### 4.1.8 Vertical stiffness

The total vertical stiffness,  $K_v$  of a laminated elastomeric isolator is the sum of the vertical deflections of the individual layers given by :

$$K_v = \frac{A'}{\sum \frac{t_i}{E_{ci}}}$$

where  $E_{ci}$  is the compression modulus.

#### 4.1.9 Horizontal stiffness

The theoretical value of the horizontal stiffness is given by :

$$K_b = \frac{GA}{T_q}$$

where

- A is the total plan area of the device;
- G is the shear modulus at the design shear strain due to earthquake-imposed horizontal displacement.

#### 4.1.10 Data analysis

The equivalent viscous damping ratio  $\xi$ , shall be expressed as:

$$\xi = \frac{2H}{\pi K_b (d^+ - d^-)^2}$$

where

$H$  is the area of the hysteresis loop.

$d^+$  and  $d^-$  are the maximum and minimum values of displacement.

# 5.0 TYPICAL BEARING SCHEDULE

Appendix

Minimum list of input required for the design of seismic bearing

	Required input	
	Lower bound	Upper bound
<b>Parameter</b>		
Axial load		
(a) Average long term		
(b) Max long term		
(c) Min long term		
(d) Max short term		
(e) Min short term		
Shear displacement		
(a) Non-seismic $d_0$		
(b) Maximum seismic (including non-seismic) $d_M$		
(c) Total maximum displacement ( $d_{max}$ ) including $d_0$ and $d_M$		
Rotation		
(a) Total non-seismic		
(b) Seismic inclusive of rotation in (a)		
Effective shear stiffness @ $d_M$		
Effective damping ratio @ $d_M$		
<b>*Information for anchorage design</b>		
Total height constraint, if any		
Seating area constraint, if any		
Upper plinth material strength		
Lower plinth material strength		
<i>*Note: If information is not given, detail of anchorage design will be excluded</i>		



# 6.0 TABLES



## 6.1.1 HIGH DAMPING RUBBER BEARING

**G = 0.6 Mpa, Damping 14%**

**Maximum Displacement = 400 mm**

Diameter (D)	Total Max Displacement ( $d_{max}$ )	Total Rubber Height ( $T_r$ )	Total Height (inclusive Endplates) (H)	Non-seismic Load @ 0mm Displacement ( $F_{z,d}$ )	Max Seismic Load ( $N_{ED,max}$ )	Vertical Stiffness ( $K_v$ )	Shear Stiffness @ 100% ( $K_h$ )	Damping ( $\zeta$ )
mm	mm	mm	mm	kN	kN	kN/mm	kN/mm	%
600	400	202	336	1,127	1,127	1,003	0.85	14
650	400	200	328	1,328	1,328	1,183	1.00	14
700	400	200	322	1,536	1,536	1,370	1.16	14
800	400	198	350	3,011	2,007	1,828	1.52	14
900	400	198	341	3,812	2,541	2,358	1.92	14
1000	400	200	360	7,846	4,707	2,917	2.37	14
1100	400	199	351	9,495	5,697	3,535	2.87	14
1200	400	198	342	11,302	6,781	4,212	3.42	14

**Maximum Displacement = 350 mm**

Diameter (D)	Total Max Displacement ( $d_{max}$ )	Total Rubber Height ( $T_r$ )	Total Height (inclusive Endplates) (H)	Non-seismic Load @ 0mm Displacement ( $F_{z,d}$ )	Max Seismic Load ( $N_{ED,max}$ )	Vertical Stiffness ( $K_v$ )	Shear Stiffness @ 100% ( $K_h$ )	Damping ( $\zeta$ )
mm	mm	mm	mm	kN	kN	kN/mm	kN/mm	%
600	350	179	303	1,127	1,127	1,135	0.96	14
650	350	175	293	1,328	1,328	1,338	1.13	14
700	350	176	288	2,304	1,536	1,550	1.31	14
800	350	177	311	3,011	2,007	2,068	1.72	14
900	350	176	310	6,354	3,812	2,711	2.17	14
1000	350	177	321	7,846	4,707	3,244	2.69	14
1100	350	176	316	9,495	5,697	3,932	3.25	14
1200	350	176	312	11,302	6,781	4,841	3.87	14

**Maximum Displacement = 300 mm**

Diameter (D)	Total Max Displacement ( $d_{max}$ )	Total Rubber Height ( $T_r$ )	Total Height (inclusive Endplates) (H)	Non-seismic Load @ 0mm Displacement ( $F_{z,d}$ )	Max Seismic Load ( $N_{ED,max}$ )	Vertical Stiffness ( $K_v$ )	Shear Stiffness @ 100% ( $K_h$ )	Damping ( $\zeta$ )
mm	mm	mm	mm	kN	kN	kN/mm	kN/mm	%
500	300	152	280	782	782	915	0.78	14
550	300	151	271	947	947	1,110	0.94	14
600	300	152	266	1,691	1,127	1,324	1.12	14
650	300	150	258	1,992	1,328	1,562	1.32	14
700	300	151	255	3,840	2,304	1,808	1.53	14
800	300	150	272	5,019	3,011	2,413	2.00	14
900	300	152	274	6,354	3,812	3,163	2.54	14
1000	300	150	282	7,846	4,707	3,850	3.13	14
1100	300	151	279	9,495	5,697	4,587	3.79	14
1200	300	151	275	11,302	6,781	5,648	4.52	14



### Maximum Displacement = 250 mm

Diameter (D)	Total Max Displacement ( $d_{max}$ )	Total Rubber Height ( $T_r$ )	Total Height (inclusive Endplates) (H)	Non-seismic Load @ 0mm Displacement ( $F_{z,d}$ )	Max Seismic Load ( $N_{ED,max}$ )	Vertical Stiffness ( $K_v$ )	Shear Stiffness @ 100% ( $K_h$ )	Damping ( $\zeta$ )
mm	mm	mm	mm	kN	kN	kN/mm	kN/mm	%
450	250	125	249	633	633	887	0.75	14
500	250	125	239	1,173	782	1,099	0.93	14
550	250	126	234	1,420	947	1,332	1.13	14
600	250	127	229	2,819	1,691	1,589	1.35	14
650	250	125	223	3,320	1,992	1,874	1.59	14
700	250	127	221	3,840	2,304	2,170	1.84	14
800	250	126	236	5,019	3,011	2,896	2.40	14
900	250	125	235	6,354	3,812	3,736	3.05	14
1000	250	126	246	7,846	4,707	4,621	3.76	14
1100	250	126	242	9,495	5,697	5,505	4.55	14
1200	250	126	238	11,302	6,781	6,672	5.42	14

### Maximum Displacement = 200 mm

Diameter (D)	Total Max Displacement ( $d_{max}$ )	Total Rubber Height ( $T_r$ )	Total Height (inclusive Endplates) (H)	Non-seismic Load @ 0mm Displacement ( $F_{z,d}$ )	Max Seismic Load ( $N_{ED,max}$ )	Vertical Stiffness ( $K_v$ )	Shear Stiffness @ 100% ( $K_h$ )	Damping ( $\zeta$ )
mm	mm	mm	mm	kN	kN	kN/mm	kN/mm	%
400	200	102	218	749	499	839	0.73	14
450	200	102	210	949	633	1,109	0.94	14
500	200	103	205	1,955	1,173	1,373	1.17	14
550	200	101	197	2,368	1,420	1,666	1.42	14
600	200	101	193	2,819	1,691	1,986	1.69	14
650	200	100	188	3,310	1,986	2,335	1.98	14
700	200	101	185	3,840	2,304	2,658	2.30	14
800	200	100	198	5,019	3,011	3,682	3.01	14

### Maximum Displacement = 150 mm

Diameter (D)	Total Max Displacement ( $d_{max}$ )	Total Rubber Height ( $T_r$ )	Total Height (inclusive Endplates) (H)	Non-seismic Load @ 0mm Displacement ( $F_{z,d}$ )	Max Seismic Load ( $N_{ED,max}$ )	Vertical Stiffness ( $K_v$ )	Shear Stiffness @ 100% ( $K_h$ )	Damping ( $\zeta$ )
mm	mm	mm	mm	kN	kN	kN/mm	kN/mm	%
300	150	76	196	419	279	648	0.55	14
350	150	75	183	954	572	888	0.76	14
400	150	75	173	1,249	749	1,141	0.99	14
450	150	76	170	1,582	949	1,507	1.26	14
500	150	76	164	1,955	1,173	1,831	1.56	14
550	150	76	160	2,368	1,420	2,221	1.89	14
600	150	77	159	2,819	1,691	2,699	2.25	14
650	150	75	153	3,310	1,986	3,114	2.64	14





**Maximum Displacement = 100 mm**

Diameter (D)	Total Max Displacement ( $d_{max}$ )	Total Rubber Height ( $T_r$ )	Total Height (inclusive Endplates) (H)	Non-seismic Load @ 0mm Displacement ( $F_{z,d}$ )	Max Seismic Load ( $N_{ED,max}$ )	Vertical Stiffness ( $K_v$ )	Shear Stiffness @ 100% ( $K_h$ )	Damping ( $\zeta$ )
mm	mm	mm	mm	kN	kN	kN/mm	kN/mm	%
300	100	50	138	699	419	859	0.83	14
350	100	51	133	954	572	1,177	1.14	14
400	100	51	125	1,249	749	1,445	1.49	14
450	100	51	125	1,582	949	2,020	1.89	14
500	100	50	118	1,955	1,173	2,191	2.34	14
550	100	50	114	2,368	1,420	2,435	2.84	14





## 6.1.2 HIGH DAMPING RUBBER BEARING

**G = 0.9 Mpa, Damping 16%**



**Maximum Displacement = 400 mm**

Diameter (D)	Total Max Displacement ( $d_{max}$ )	Total Rubber Height ( $T_r$ )	Total Height (inclusive Endplates) (H)	Non-seismic Load @ 0mm Displacement ( $F_{z,d}$ )	Max Seismic Load ( $N_{ED,max}$ )	Vertical Stiffness ( $K_v$ )	Shear Stiffness @ 100% ( $K_h$ )	Damping ( $\zeta$ )
mm	mm	mm	mm	kN	kN	kN/mm	kN/mm	%
600	400	202	342	1,127	1,127	1,112	1.28	16
650	400	200	334	1,328	1,328	1,311	1.50	16
700	400	200	328	1,536	1,536	1,518	1.74	16
800	400	198	350	3,011	2,007	2,014	2.28	16
900	400	198	345	3,812	2,541	2,586	2.88	16
1000	400	200	374	7,846	4,707	3,197	3.56	16
1100	400	199	361	9,495	5,697	3,873	4.31	16
1200	400	198	352	11,302	6,781	4,614	5.13	16

**Maximum Displacement = 350 mm**

Diameter (D)	Total Max Displacement ( $d_{max}$ )	Total Rubber Height ( $T_r$ )	Total Height (inclusive Endplates) (H)	Non-seismic Load @ 0mm Displacement ( $F_{z,d}$ )	Max Seismic Load ( $N_{ED,max}$ )	Vertical Stiffness ( $K_v$ )	Shear Stiffness @ 100% ( $K_h$ )	Damping ( $\zeta$ )
mm	mm	mm	mm	kN	kN	kN/mm	kN/mm	%
600	350	179	309	1,127	1,127	1,258	1.45	16
650	350	175	299	1,328	1,328	1,483	1.70	16
700	350	176	298	2,304	1,536	1,717	1.97	16
800	350	177	321	3,011	2,007	2,279	2.58	16
900	350	176	324	6,354	3,812	2,960	3.26	16
1000	350	177	335	7,846	4,707	3,572	4.03	16
1100	350	176	326	9,495	5,697	4,328	4.88	16
1200	350	176	322	11,302	6,781	5,281	5.81	16

**Maximum Displacement = 300 mm**

Diameter (D)	Total Max Displacement ( $d_{max}$ )	Total Rubber Height ( $T_r$ )	Total Height (inclusive Endplates) (H)	Non-seismic Load @ 0mm Displacement ( $F_{z,d}$ )	Max Seismic Load ( $N_{ED,max}$ )	Vertical Stiffness ( $K_v$ )	Shear Stiffness @ 100% ( $K_h$ )	Damping ( $\zeta$ )
mm	mm	mm	mm	kN	kN	kN/mm	kN/mm	%
500	300	152	286	782	782	1,016	1.17	16
550	300	151	277	947	947	1,231	1.42	16
600	300	152	272	1,691	1,127	1,468	1.69	16
650	300	150	264	1,992	1,328	1,731	1.99	16
700	300	151	265	3,840	2,304	2,004	2.30	16
800	300	150	282	5,019	3,011	2,659	3.01	16
900	300	152	288	6,354	3,812	3,454	3.81	16
1000	300	150	296	7,846	4,707	4,220	4.70	16
1100	300	151	289	9,495	5,697	5,049	5.69	16
1200	300	151	285	11,302	6,781	6,161	6.78	16



### Maximum Displacement = 250 mm

Diameter (D)	Total Max Displacement ( $d_{max}$ )	Total Rubber Height ( $T_r$ )	Total Height (inclusive Endplates) (H)	Non-seismic Load @ 0mm Displacement ( $F_{z,d}$ )	Max Seismic Load ( $N_{ED,max}$ )	Vertical Stiffness ( $K_v$ )	Shear Stiffness @ 100% ( $K_h$ )	Damping ( $\zeta$ )
mm	mm	mm	mm	kN	kN	kN/mm	kN/mm	%
450	250	125	255	633	633	985	1.13	16
500	250	125	245	1,173	782	1,219	1.40	16
550	250	126	240	1,420	947	1,478	1.70	16
600	250	127	235	2,819	1,691	1,762	2.03	16
650	250	125	229	3,320	1,992	2,077	2.39	16
700	250	127	231	3,840	2,304	2,405	2.76	16
800	250	126	246	5,019	3,011	3,191	3.61	16
900	250	125	249	6,354	3,812	4,097	4.57	16
1000	250	126	260	7,846	4,707	5,065	5.64	16
1100	250	126	252	9,495	5,697	6,059	6.83	16
1200	250	126	248	11,302	6,781	7,309	8.13	16

### Maximum Displacement = 200 mm

Diameter (D)	Total Max Displacement ( $d_{max}$ )	Total Rubber Height ( $T_r$ )	Total Height (inclusive Endplates) (H)	Non-seismic Load @ 0mm Displacement ( $F_{z,d}$ )	Max Seismic Load ( $N_{ED,max}$ )	Vertical Stiffness ( $K_v$ )	Shear Stiffness @ 100% ( $K_h$ )	Damping ( $\zeta$ )
mm	mm	mm	mm	kN	kN	kN/mm	kN/mm	%
400	200	102	224	749	499	936	1.10	16
450	200	102	216	949	633	1,231	1.42	16
500	200	103	211	1,955	1,173	1,524	1.76	16
550	200	101	203	2,368	1,420	1,847	2.13	16
600	200	101	199	2,819	1,691	2,202	2.53	16
650	200	100	198	3,310	1,986	2,588	2.97	16
700	200	101	195	3,840	2,304	2,961	3.45	16
800	200	100	208	5,019	3,011	4,039	4.51	16

### Maximum Displacement = 150 mm

Diameter (D)	Total Max Displacement ( $d_{max}$ )	Total Rubber Height ( $T_r$ )	Total Height (inclusive Endplates) (H)	Non-seismic Load @ 0mm Displacement ( $F_{z,d}$ )	Max Seismic Load ( $N_{ED,max}$ )	Vertical Stiffness ( $K_v$ )	Shear Stiffness @ 100% ( $K_h$ )	Damping ( $\zeta$ )
mm	mm	mm	mm	kN	kN	kN/mm	kN/mm	%
300	150	76	202	419	279	721	0.83	16
350	150	75	189	954	572	986	1.14	16
400	150	75	179	1,249	749	1,273	1.49	16
450	150	76	176	1,582	949	1,665	1.89	16
500	150	76	170	1,955	1,173	2,032	2.34	16
550	150	76	166	2,368	1,420	2,463	2.84	16
600	150	77	165	2,819	1,691	2,978	3.38	16
650	150	75	163	3,310	1,986	3,451	3.97	16





Maximum Displacement = 100 mm

Diameter (D)	Total Max Displacement ( $d_{max}$ )	Total Rubber Height ( $T_r$ )	Total Height (inclusive Endplates) (H)	Non-seismic Load @ 0mm Displacement ( $F_{z,d}$ )	Max Seismic Load ( $N_{ED,max}$ )	Vertical Stiffness ( $K_v$ )	Shear Stiffness @ 100% ( $K_h$ )	Damping ( $\zeta$ )
mm	mm	mm	mm	kN	kN	kN/mm	kN/mm	%
300	100	50	144	699	419	985	1.25	16
350	100	51	139	954	572	1,348	1.71	16
400	100	51	131	1,249	749	1,680	2.24	16
450	100	51	131	1,582	949	2,296	2.84	16
500	100	50	124	1,955	1,173	2,566	3.52	16
550	100	50	120	2,368	1,420	2,905	4.26	16



## 6.1.3 HIGH DAMPING RUBBER BEARING

**G = 1.1 Mpa, Damping 17%**



### Maximum Displacement = 400 mm

Diameter (D)	Total Max Displacement ( $d_{max}$ )	Total Rubber Height ( $T_r$ )	Total Height (inclusive Endplates) (H)	Non-seismic Load @ 0mm Displacement ( $F_{z,d}$ )	Max Seismic Load ( $N_{ED,max}$ )	Vertical Stiffness ( $K_v$ )	Shear Stiffness @ 100% ( $K_h$ )	Damping ( $\zeta$ )
mm	mm	mm	mm	kN	kN	kN/mm	kN/mm	%
600	400	202	342	1,122	1,122	1,132	1.55	17
650	400	200	334	1,323	1,323	1,335	1.83	17
700	400	200	328	1,531	1,531	1,547	2.12	17
800	400	198	350	3,003	2,002	2,053	2.78	17
900	400	198	345	3,804	2,536	2,635	3.52	17
1000	400	200	374	7,833	4,700	3,294	4.35	17
1100	400	199	361	9,482	5,689	3,948	5.26	17
1200	400	198	352	11,289	6,773	4,705	6.27	17

### Maximum Displacement = 350 mm

Diameter (D)	Total Max Displacement ( $d_{max}$ )	Total Rubber Height ( $T_r$ )	Total Height (inclusive Endplates) (H)	Non-seismic Load @ 0mm Displacement ( $F_{z,d}$ )	Max Seismic Load ( $N_{ED,max}$ )	Vertical Stiffness ( $K_v$ )	Shear Stiffness @ 100% ( $K_h$ )	Damping ( $\zeta$ )
mm	mm	mm	mm	kN	kN	kN/mm	kN/mm	%
600	350	179	309	1,122	1,122	1,281	1.76	17
650	350	175	299	1,323	1,323	1,511	2.07	17
700	350	176	298	2,296	1,531	1,750	2.40	17
800	350	177	321	3,003	2,002	2,323	3.14	17
900	350	176	324	6,341	3,804	3,014	3.98	17
1000	350	177	335	7,833	4,700	3,687	4.92	17
1100	350	176	326	9,482	5,689	4,467	5.96	17
1200	350	176	322	11,289	6,773	5,381	7.09	17

### Maximum Displacement = 300 mm

Diameter (D)	Total Max Displacement ( $d_{max}$ )	Total Rubber Height ( $T_r$ )	Total Height (inclusive Endplates) (H)	Non-seismic Load @ 0mm Displacement ( $F_{z,d}$ )	Max Seismic Load ( $N_{ED,max}$ )	Vertical Stiffness ( $K_v$ )	Shear Stiffness @ 100% ( $K_h$ )	Damping ( $\zeta$ )
mm	mm	mm	mm	kN	kN	kN/mm	kN/mm	%
500	300	152	286	777	777	1,032	1.42	17
550	300	151	277	942	942	1,253	1.72	17
600	300	152	272	1,684	1,122	1,494	2.05	17
650	300	150	264	1,984	1,323	1,763	2.42	17
700	300	151	265	3,828	2,296	2,042	2.80	17
800	300	150	282	5,006	3,003	2,710	3.67	17
900	300	152	288	6,341	3,804	3,516	4.65	17
1000	300	150	296	7,833	4,700	4,301	5.74	17
1100	300	151	289	9,482	5,689	5,212	6.95	17
1200	300	151	285	11,289	6,773	6,278	8.27	17





### Maximum Displacement = 250 mm

Diameter (D)	Total Max Displacement ( $d_{max}$ )	Total Rubber Height ( $T_r$ )	Total Height (inclusive Endplates) (H)	Non-seismic Load @ 0mm Displacement ( $F_{z,d}$ )	Max Seismic Load ( $N_{ED,max}$ )	Vertical Stiffness ( $K_v$ )	Shear Stiffness @ 100% ( $K_h$ )	Damping ( $\zeta$ )
mm	mm	mm	mm	kN	kN	kN/mm	kN/mm	%
450	250	125	255	628	628	999	1.38	17
500	250	125	245	1,165	777	1,221	1.70	17
550	250	126	240	1,413	942	1,503	2.07	17
600	250	127	235	2,807	1,684	1,793	2.47	17
650	250	125	229	3,308	1,984	2,116	2.91	17
700	250	127	231	3,828	2,296	2,450	3.36	17
800	250	126	246	5,006	3,003	3,291	4.40	17
900	250	125	249	6,341	3,804	4,219	5.58	17
1000	250	126	260	7,833	4,700	5,218	6.89	17
1100	250	126	252	9,482	5,689	6,255	8.34	17
1200	250	126	248	11,289	6,773	7,533	9.93	17

### Maximum Displacement = 200 mm

Diameter (D)	Total Max Displacement ( $d_{max}$ )	Total Rubber Height ( $T_r$ )	Total Height (inclusive Endplates) (H)	Non-seismic Load @ 0mm Displacement ( $F_{z,d}$ )	Max Seismic Load ( $N_{ED,max}$ )	Vertical Stiffness ( $K_v$ )	Shear Stiffness @ 100% ( $K_h$ )	Damping ( $\zeta$ )
mm	mm	mm	mm	kN	kN	kN/mm	kN/mm	%
400	200	102	224	741	494	934	1.33	17
450	200	102	216	942	628	1,231	1.72	17
500	200	103	211	1,943	1,165	1,548	2.13	17
550	200	101	203	2,355	1,413	1,879	2.59	17
600	200	101	199	2,807	1,684	2,242	3.08	17
650	200	100	198	3,297	1,978	2,637	3.62	17
700	200	101	195	3,828	2,296	3,020	4.21	17
800	200	100	208	5,006	3,003	4,114	5.50	17

### Maximum Displacement = 150 mm

Diameter (D)	Total Max Displacement ( $d_{max}$ )	Total Rubber Height ( $T_r$ )	Total Height (inclusive Endplates) (H)	Non-seismic Load @ 0mm Displacement ( $F_{z,d}$ )	Max Seismic Load ( $N_{ED,max}$ )	Vertical Stiffness ( $K_v$ )	Shear Stiffness @ 100% ( $K_h$ )	Damping ( $\zeta$ )
mm	mm	mm	mm	kN	kN	kN/mm	kN/mm	%
300	150	76	202	411	274	702	1.00	17
350	150	75	189	941	565	981	1.38	17
400	150	75	179	1,236	741	1,270	1.81	17
450	150	76	176	1,570	942	1,666	2.30	17
500	150	76	170	1,943	1,165	2,064	2.84	17
550	150	76	166	2,355	1,413	2,506	3.45	17
600	150	77	165	2,807	1,684	3,029	4.11	17
650	150	75	163	3,297	1,978	3,516	4.83	17



**Maximum Displacement = 100 mm**

Diameter (D)	Total Max Displacement ( $d_{max}$ )	Total Rubber Height ( $T_r$ )	Total Height (inclusive Endplates) (H)	Non-seismic Load @ 0mm Displacement ( $F_{z,d}$ )	Max Seismic Load ( $N_{ED,max}$ )	Vertical Stiffness ( $K_v$ )	Shear Stiffness @ 100% ( $K_h$ )	Damping ( $\zeta$ )
mm	mm	mm	mm	kN	kN	kN/mm	kN/mm	%
300	100	50	144	686	411	969	1.51	17
350	100	51	139	941	565	1,366	2.07	17
400	100	51	131	1,236	741	1,659	2.71	17
450	100	51	131	1,570	942	2,336	3.45	17
500	100	50	124	1,943	1,165	2,620	4.27	17
550	100	50	120	2,355	1,413	2,969	5.18	17





## 6.2.1 LEAD RUBBER BEARING

**G = 0.4 Mpa, Damping 10%**



### Maximum Displacement = 400 mm

Diameter (D)	Total Max Displacement (d <sub>max</sub> )	Total Rubber Height (T <sub>r</sub> )	Total Height (inclusive Endplates) (H)	Maximum Axial Load (F <sub>z,d</sub> )	Nominal Axial Load (N <sub>ED</sub> )	Post-elastic Stiffness @ 100% (K <sub>d</sub> )	Characteristic Strength (Q <sub>d</sub> )	Effective Stiffness @ 100% (K <sub>h</sub> )	Damping (ζ)
mm	mm	mm	mm	kN	kN	kN/mm	kN	kN/mm	%
700	400	164	330	4,100	2,200	0.926	29	1.105	10
800	400	165	320	6,800	2,900	1.202	42	1.459	10
900	400	165	320	10,100	3,600	1.534	52	1.851	10
1000	400	195	360	13,500	4,500	1.600	63	1.925	10
1100	400	195	350	16,800	5,400	1.943	82	2.363	10
1200	400	199	344	20,000	6,500	2.266	82	2.677	10

### Maximum Displacement = 350 mm

Diameter (D)	Total Max Displacement (d <sub>max</sub> )	Total Rubber Height (T <sub>r</sub> )	Total Height (inclusive Endplates) (H)	Maximum Axial Load (F <sub>z,d</sub> )	Nominal Axial Load (N <sub>ED</sub> )	Post-elastic Stiffness @ 100% (K <sub>d</sub> )	Characteristic Strength (Q <sub>d</sub> )	Effective Stiffness @ 100% (K <sub>h</sub> )	Damping (ζ)
mm	mm	mm	mm	kN	kN	kN/mm	kN	kN/mm	%
700	350	149	275	4,100	2,200	1.010	29	1.207	10
800	350	148	270	6,800	2,900	1.344	42	1.630	10
900	350	145	270	10,100	3,600	1.744	52	2.105	10
1000	350	176	310	13,500	4,500	1.779	63	2.138	10
1100	350	170	300	16,800	5,400	2.231	82	2.711	10
1200	350	190	330	20,000	6,500	2.375	82	2.805	10

### Maximum Displacement = 300 mm

Diameter (D)	Total Max Displacement (d <sub>max</sub> )	Total Rubber Height (T <sub>r</sub> )	Total Height (inclusive Endplates) (H)	Maximum Axial Load (F <sub>z,d</sub> )	Nominal Axial Load (N <sub>ED</sub> )	Post-elastic Stiffness @ 100% (K <sub>d</sub> )	Characteristic Strength (Q <sub>d</sub> )	Effective Stiffness @ 100% (K <sub>h</sub> )	Damping (ζ)
mm	mm	mm	mm	kN	kN	kN/mm	kN	kN/mm	%
650	300	130	240	3,300	1,900	0.991	26	1.188	10
700	300	128	230	4,100	2,200	1.173	29	1.403	10
800	300	134	240	6,800	2,900	1.483	42	1.800	10
900	300	130	240	10,100	3,600	1.947	52	2.349	10
1000	300	151	265	13,500	4,500	2.076	63	2.495	10
1100	300	172	290	16,800	5,400	2.206	82	2.681	10
1200	300	170	300	20,000	6,500	2.659	82	3.140	10



### Maximum Displacement = 250 mm

Diameter (D)	Total Max Displacement ( $d_{max}$ )	Total Rubber Height ( $T_r$ )	Total Height (inclusive Endplates) (H)	Maximum Axial Load ( $F_{z,d}$ )	Nominal Axial Load ( $N_{ED}$ )	Post-elastic Stiffness @ 100% ( $K_d$ )	Characteristic Strength ( $Q_d$ )	Effective Stiffness @ 100% ( $K_h$ )	Damping ( $\zeta$ )
mm	mm	mm	mm	kN	kN	kN/mm	kN	kN/mm	%
550	250	108	210	2,000	1,370	0.845	19	1.019	10
600	250	112	210	2,600	1,630	0.974	22	1.171	10
650	250	117	215	3,300	1,900	1.103	26	1.322	10
700	250	110	200	4,100	2,200	1.372	29	1.639	10
800	250	112	210	6,800	2,900	1.787	42	2.165	10
900	250	115	220	10,100	3,600	2.208	52	2.663	10
1000	250	126	220	13,500	4,500	2.489	63	2.991	10
1100	250	150	260	16,800	5,400	2.535	82	3.080	10
1200	250	166	280	20,000	6,500	2.725	82	3.217	10

### Maximum Displacement = 200 mm

Diameter (D)	Total Max Displacement ( $d_{max}$ )	Total Rubber Height ( $T_r$ )	Total Height (inclusive Endplates) (H)	Maximum Axial Load ( $F_{z,d}$ )	Nominal Axial Load ( $N_{ED}$ )	Post-elastic Stiffness @ 100% ( $K_d$ )	Characteristic Strength ( $Q_d$ )	Effective Stiffness @ 100% ( $K_h$ )	Damping ( $\zeta$ )
mm	mm	mm	mm	kN	kN	kN/mm	kN	kN/mm	%
450	200	84	190	1,550	910	0.735	13	0.891	10
500	200	85	195	2,000	1,130	0.902	16	1.088	10
550	200	88	170	2,000	1,370	1.036	19	1.250	10
600	200	84	170	3,500	1,630	1.327	22	1.590	10
650	200	88	170	4,100	1,900	1.485	26	1.777	10
700	200	88	165	5,400	2,200	1.738	29	2.072	10
800	200	88	170	6,800	2,900	2.280	42	2.761	10

### Maximum Displacement = 150 mm

Diameter (D)	Total Max Displacement ( $d_{max}$ )	Total Rubber Height ( $T_r$ )	Total Height (inclusive Endplates) (H)	Maximum Axial Load ( $F_{z,d}$ )	Nominal Axial Load ( $N_{ED}$ )	Post-elastic Stiffness @ 100% ( $K_d$ )	Characteristic Strength ( $Q_d$ )	Effective Stiffness @ 100% ( $K_h$ )	Damping ( $\zeta$ )
mm	mm	mm	mm	kN	kN	kN/mm	kN	kN/mm	%
450	150	68	150	1,400	910	0.904	13	1.096	10
500	150	71	153	2,000	1,130	1.080	16	1.303	10
550	150	72	150	2,700	1,370	1.295	19	1.556	10
600	150	74	160	4,500	1,630	1.519	22	1.817	10
650	150	69	147	5,000	1,900	1.916	26	2.287	10



## 6.2.2 LEAD RUBBER BEARING

**G = 0.4 Mpa, Damping 16%**



### Maximum Displacement = 400 mm

Diameter (D)	Total Max Displacement ( $d_{max}$ )	Total Rubber Height ( $T_r$ )	Total Height (inclusive Endplates) (H)	Maximum Axial Load ( $F_{z,d}$ )	Nominal Axial Load ( $N_{ED}$ )	Post-elastic Stiffness @ 100% ( $K_d$ )	Characteristic Strength ( $Q_d$ )	Effective Stiffness @ 100% ( $K_h$ )	Damping ( $\zeta$ )
mm	mm	mm	mm	kN	kN	kN/mm	kN	kN/mm	%
700	400	164	330	3,900	2,200	0.929	52	1.248	16
800	400	165	320	6,800	2,900	1.206	69	1.625	16
900	400	165	320	10,100	3,600	1.541	94	2.113	16
1000	400	195	360	13,500	4,500	1.608	115	2.199	16
1100	400	195	350	16,800	5,400	1.951	138	2.661	16
1200	400	199	344	20,000	6,500	2.277	164	3.098	16

### Maximum Displacement = 350 mm

Diameter (D)	Total Max Displacement ( $d_{max}$ )	Total Rubber Height ( $T_r$ )	Total Height (inclusive Endplates) (H)	Maximum Axial Load ( $F_{z,d}$ )	Nominal Axial Load ( $N_{ED}$ )	Post-elastic Stiffness @ 100% ( $K_d$ )	Characteristic Strength ( $Q_d$ )	Effective Stiffness @ 100% ( $K_h$ )	Damping ( $\zeta$ )
mm	mm	mm	mm	kN	kN	kN/mm	kN	kN/mm	%
700	350	149	275	4,100	2,200	1.013	52	1.364	16
800	350	148	270	6,800	2,900	1.349	69	1.816	16
900	350	145	270	10,100	3,600	1.752	94	2.403	16
1000	350	176	310	13,500	4,500	1.787	115	2.442	16
1100	350	170	300	16,800	5,400	2.239	138	3.053	16
1200	350	190	330	20,000	6,500	2.387	164	3.247	16

### Maximum Displacement = 300 mm

Diameter (D)	Total Max Displacement ( $d_{max}$ )	Total Rubber Height ( $T_r$ )	Total Height (inclusive Endplates) (H)	Maximum Axial Load ( $F_{z,d}$ )	Nominal Axial Load ( $N_{ED}$ )	Post-elastic Stiffness @ 100% ( $K_d$ )	Characteristic Strength ( $Q_d$ )	Effective Stiffness @ 100% ( $K_h$ )	Damping ( $\zeta$ )
mm	mm	mm	mm	kN	kN	kN/mm	kN	kN/mm	%
650	300	130	240	3,300	1,900	0.995	47	1.358	16
700	300	128	230	4,100	2,200	1.178	52	1.586	16
800	300	134	240	6,800	2,900	1.488	69	2.005	16
900	300	130	240	10,100	3,600	1.955	94	2.681	16
1000	300	151	265	13,500	4,500	2.085	115	2.849	16
1100	300	172	290	16,800	5,400	2.215	138	3.019	16
1200	300	170	300	20,000	6,500	2.672	164	3.633	16



### Maximum Displacement = 250 mm

Diameter (D)	Total Max Displacement ( $d_{max}$ )	Total Rubber Height ( $T_r$ )	Total Height (inclusive Endplates) (H)	Maximum Axial Load ( $F_{z,d}$ )	Nominal Axial Load ( $N_{ED}$ )	Post-elastic Stiffness @ 100% ( $K_d$ )	Characteristic Strength ( $Q_d$ )	Effective Stiffness @ 100% ( $K_h$ )	Damping ( $\zeta$ )
mm	mm	mm	mm	kN	kN	kN/mm	kN	kN/mm	%
550	250	108	210	2,000	1,370	0.847	34	1.157	16
600	250	112	210	2,600	1,630	0.977	38	1.314	16
650	250	117	215	3,300	1,900	1.107	47	1.511	16
700	250	110	200	4,100	2,200	1.377	52	1.852	16
800	250	112	210	6,800	2,900	1.793	69	2.410	16
900	250	115	220	10,100	3,600	2.218	94	3.039	16
1000	250	126	220	13,500	4,500	2.500	115	3.415	16
1100	250	150	260	16,800	5,400	2.545	138	3.468	16
1200	250	166	280	20,000	6,500	2.738	164	3.722	16

### Maximum Displacement = 200 mm

Diameter (D)	Total Max Displacement ( $d_{max}$ )	Total Rubber Height ( $T_r$ )	Total Height (inclusive Endplates) (H)	Maximum Axial Load ( $F_{z,d}$ )	Nominal Axial Load ( $N_{ED}$ )	Post-elastic Stiffness @ 100% ( $K_d$ )	Characteristic Strength ( $Q_d$ )	Effective Stiffness @ 100% ( $K_h$ )	Damping ( $\zeta$ )
mm	mm	mm	mm	kN	kN	kN/mm	kN	kN/mm	%
450	200	84	190	1,550	910	0.737	22	1.000	16
500	200	85	195	2,000	1,130	0.905	29	1.251	16
550	200	88	170	2,000	1,370	1.040	34	1.420	16
600	200	84	170	3,500	1,630	1.331	38	1.781	16
650	200	88	170	4,100	1,900	1.491	47	2.028	16
700	200	88	165	5,400	2,200	1.745	52	2.339	16
800	200	88	170	6,800	2,900	2.288	69	3.074	16

### Maximum Displacement = 150 mm

Diameter (D)	Total Max Displacement ( $d_{max}$ )	Total Rubber Height ( $T_r$ )	Total Height (inclusive Endplates) (H)	Maximum Axial Load ( $F_{z,d}$ )	Nominal Axial Load ( $N_{ED}$ )	Post-elastic Stiffness @ 100% ( $K_d$ )	Characteristic Strength ( $Q_d$ )	Effective Stiffness @ 100% ( $K_h$ )	Damping ( $\zeta$ )
mm	mm	mm	mm	kN	kN	kN/mm	kN	kN/mm	%
450	150	68	150	1,400	910	0.907	22	1.232	16
500	150	71	153	2,000	1,130	1.085	29	1.499	16
550	150	72	150	2,700	1,370	1.299	34	1.764	16
600	150	74	160	4,500	1,630	1.524	38	2.035	16
650	150	69	147	5,000	1,900	1.924	47	2.608	16



## 6.2.3 LEAD RUBBER BEARING

**G = 0.4 Mpa, Damping 24%**



### Maximum Displacement = 400 mm

Diameter (D)	Total Max Displacement ( $d_{max}$ )	Total Rubber Height ( $T_r$ )	Total Height (inclusive Endplates) (H)	Maximum Axial Load ( $F_{z,d}$ )	Nominal Axial Load ( $N_{ED}$ )	Post-elastic Stiffness @ 100% ( $K_d$ )	Characteristic Strength ( $Q_d$ )	Effective Stiffness @ 100% ( $K_h$ )	Damping ( $\zeta$ )
mm	mm	mm	mm	kN	kN	kN/mm	kN	kN/mm	%
700	400	160	330	3,800	2,200	0.964	105	1.618	24
800	400	160	320	6,800	2,900	1.259	138	2.124	24
900	400	165	320	10,100	3,600	1.556	189	2.700	24
1000	400	195	360	13,500	4,500	1.623	231	2.806	24
1100	400	195	350	16,800	5,400	1.970	277	3.389	24
1200	400	199	344	20,000	6,500	2.299	327	3.941	24

### Maximum Displacement = 350 mm

Diameter (D)	Total Max Displacement ( $d_{max}$ )	Total Rubber Height ( $T_r$ )	Total Height (inclusive Endplates) (H)	Maximum Axial Load ( $F_{z,d}$ )	Nominal Axial Load ( $N_{ED}$ )	Post-elastic Stiffness @ 100% ( $K_d$ )	Characteristic Strength ( $Q_d$ )	Effective Stiffness @ 100% ( $K_h$ )	Damping ( $\zeta$ )
mm	mm	mm	mm	kN	kN	kN/mm	kN	kN/mm	%
700	350	149	275	3,800	2,200	1.021	105	1.724	24
800	350	148	270	6,800	2,900	1.360	138	2.295	24
900	350	145	270	10,100	3,600	1.768	189	3.071	24
1000	350	176	310	13,500	4,500	1.804	231	3.114	24
1100	350	170	300	16,800	5,400	2.261	277	3.888	24
1200	350	190	330	20,000	6,500	2.409	327	4.130	24

### Maximum Displacement = 300 mm

Diameter (D)	Total Max Displacement ( $d_{max}$ )	Total Rubber Height ( $T_r$ )	Total Height (inclusive Endplates) (H)	Maximum Axial Load ( $F_{z,d}$ )	Nominal Axial Load ( $N_{ED}$ )	Post-elastic Stiffness @ 100% ( $K_d$ )	Characteristic Strength ( $Q_d$ )	Effective Stiffness @ 100% ( $K_h$ )	Damping ( $\zeta$ )
mm	mm	mm	mm	kN	kN	kN/mm	kN	kN/mm	%
650	300	130	240	3,000	1,900	1.003	94	1.729	24
700	300	128	230	4,100	2,200	1.187	105	2.004	24
800	300	134	240	6,800	2,900	1.501	138	2.534	24
900	300	130	240	10,100	3,600	1.974	189	3.426	24
1000	300	151	265	13,500	4,500	2.105	231	3.633	24
1100	300	172	290	16,800	5,400	2.236	277	3.844	24
1200	300	170	300	20,000	6,500	2.697	327	4.621	24



### Maximum Displacement = 250 mm

Diameter (D)	Total Max Displacement ( $d_{max}$ )	Total Rubber Height ( $T_r$ )	Total Height (inclusive Endplates) (H)	Maximum Axial Load ( $F_{z,d}$ )	Nominal Axial Load ( $N_{ED}$ )	Post-elastic Stiffness @ 100% ( $K_d$ )	Characteristic Strength ( $Q_d$ )	Effective Stiffness @ 100% ( $K_h$ )	Damping ( $\zeta$ )
mm	mm	mm	mm	kN	kN	kN/mm	kN	kN/mm	%
550	250	108	210	2,000	1,370	0.854	67	1.474	24
600	250	112	210	2,600	1,630	0.984	76	1.659	24
650	250	117	215	3,300	1,900	1.116	94	1.923	24
700	250	110	200	4,100	2,200	1.388	105	2.339	24
800	250	112	210	6,800	2,900	1.809	138	3.044	24
900	250	115	220	10,100	3,600	2.239	189	3.881	24
1000	250	126	220	13,500	4,500	2.524	231	4.355	24
1100	250	150	260	16,800	5,400	2.570	277	4.415	24
1200	250	166	280	20,000	6,500	2.764	327	4.733	24

### Maximum Displacement = 200 mm

Diameter (D)	Total Max Displacement ( $d_{max}$ )	Total Rubber Height ( $T_r$ )	Total Height (inclusive Endplates) (H)	Maximum Axial Load ( $F_{z,d}$ )	Nominal Axial Load ( $N_{ED}$ )	Post-elastic Stiffness @ 100% ( $K_d$ )	Characteristic Strength ( $Q_d$ )	Effective Stiffness @ 100% ( $K_h$ )	Damping ( $\zeta$ )
mm	mm	mm	mm	kN	kN	kN/mm	kN	kN/mm	%
450	200	84	190	1,400	910	0.743	42	1.247	24
500	200	85	195	2,000	1,130	0.913	58	1.591	24
550	200	88	170	2,000	1,370	1.047	67	1.808	24
600	200	84	170	3,500	1,630	1.342	76	2.242	24
650	200	88	170	4,100	1,900	1.491	94	2.028	24
700	200	88	165	5,400	2,200	1.760	105	2.949	24
800	200	88	170	6,800	2,900	2.308	138	3.881	24

### Maximum Displacement = 150 mm

Diameter (D)	Total Max Displacement ( $d_{max}$ )	Total Rubber Height ( $T_r$ )	Total Height (inclusive Endplates) (H)	Maximum Axial Load ( $F_{z,d}$ )	Nominal Axial Load ( $N_{ED}$ )	Post-elastic Stiffness @ 100% ( $K_d$ )	Characteristic Strength ( $Q_d$ )	Effective Stiffness @ 100% ( $K_h$ )	Damping ( $\zeta$ )
mm	mm	mm	mm	kN	kN	kN/mm	kN	kN/mm	%
450	150	68	150	1,400	910	0.913	42	1.536	24
500	150	71	153	2,000	1,130	1.094	58	1.906	24
550	150	72	150	2,700	1,370	1.310	67	2.240	24
600	150	74	160	4,500	1,630	1.537	76	2.559	24
650	150	69	147	5,000	1,900	1.942	94	3.310	24



# 7.0 MATERIAL SPECIFICATION

## Mechanical and physical properties of High Damping Elastomers

Property	Requirement		Test Method
	Moulded Sample	Test piece from device <sup>d</sup>	
Tensile strength (MPa), min.	12	10	ISO 37 Type 2
Elongation at break (%), min.	400	350	ISO 37 Type 2
Tear resistance (kN/m), min	7		ISO 34 <sup>c</sup> Method A
Compression set 70 °C, 24 h, max.	60		ISO 815 Type A 25% compression
Ozone resistance <sup>a</sup> Elongation 30 % - 96 h 40 °C ± 2 °C	no cracks		ISO 1431-1
Accelerated air oven ageing <sup>b</sup> Maximum change from unaged value			ISO 188, Method A
Hardness (IRHD)	-5, +8		ISO 48
Tensile strength (%)	± 15		ISO 37 Type 2
Elongation at break (%)	± 25		ISO 37 Type 2
NOTE	Because the ozone and ageing tests are checks that appropriate antidegradants have been included, not tests related to service performance, their effectiveness necessitates that the conditions should be appropriate to the elastomer used in manufacture of the devices.		
a	The ozone concentration shall be appropriate to the elastomers used. For natural rubber based vulcanisates, 25 ppm shall be used and for polychloroprene based vulcanisates 100 ppm. For other elastomers, the values shall be agreed between the manufacturer and the structural engineer. For elastomers with no unsaturated carbon-carbon bonds, an ozone test need not be performed.		
b	Ageing condition shall be chosen appropriate to elastomers used. For natural rubber based vulcanisates, 7 days at 70 °C shall be used and for polychloroprene based vulcanisates, 3 days at 100 °C. For other elastomers, the values shall be agreed between the manufacturer and the structural engineer.		
c	If the legs of the test piece extend without the initial cut growing, the method shall be modified to reduce the extension and ensure cut growth by either increasing the width of the legs or fixing a flexible but relatively inextensible reinforcement to the test piece; the reinforcement shall leave a gap of 5 mm where the tear is expected to grow.		
d	Test pieces from complete finished isolators shall be taken from the first internal layer and from the layer at the centre of the isolator.		



# 8.0 TESTING METHOD

## TESTING METHOD ACCORDANCE TO EN 15129

Test	Type test requirements	Factory production control test requirements
Capacity in compression under zero lateral displacement	Support $N_{sd}$ . No defects visible. See 8.2.1.2.6.	N/A
Compression stiffness	Report value. See 8.2.1.2.8.	Within $\pm 30\%$ of type test value. No defects visible. See 8.2.1.2.8
*Horizontal characteristics $K_b$ and $\xi_b$ (or $K_2$ and $Q_d$ ) under cyclic deformation	Report strain dependence. At design displacement, $d_{bd}$ , values within $\pm 20\%$ of design value. See 8.2.1.2.2	Values within $\pm 20\%$ of required values. See 8.2.1.2.2
*Horizontal stiffness under a one-sided ramp loading (Required if cyclic horizontal stiffness and damping from production control test not measured at shear strain amplitude close to value corresponding to, $d_{bd}$ )	Report value at design displacement, $d_{bd}$ . See 8.2.1.2.2	Within $\pm 20\%$ of adjusted type test value. See 8.2.1.2.2
Variation of horizontal characteristics $K_b$ and $\xi_b$ (or $K_2$ and $Q_d$ ) with frequency	Report variation. Maximum variation $\pm 20\%$ . See 8.2.1.2.3	N/A
*Variation of horizontal characteristics $K_b$ and $\xi_b$ (or $K_2$ and $Q_d$ ) with temperature	Report variation. Maximum variation within limits set in 8.2.1.2.4	N/A
Dependence of horizontal characteristics $K_b$ and $\xi_b$ (or $K_2$ and $Q_d$ ) on repeated cycling	Dependence within limits specified in 8.2.1.2.5	N/A
*Lateral capacity under maximum and minimum vertical loads	Force-displacement curve increasing up to $\frac{1}{2}d_{Ed}$ . No defects. See 8.2.1.2.7.	N/A
Change of horizontal characteristics $K_b$ and $\xi_b$ of the isolator (or $K_2$ only for LRB manufactured using low damping elastomer) due to ageing	Change $\leq 20\%$	N/A
Creep test under vertical load	Total Creep rate $< 20\%$ per decade. See 8.2.1.2.10.	N/A
<sup>a</sup> Optional test N/A = Not Applicable		*For low damping bridge isolators subjected to small seismic actions, only the tests marked with * shall apply. See 8.2.1.2.11 for requirements.



# 9.0 RESTRAINT & ANCHORAGE DESIGN

Sometimes, certain project requires the High Damping Rubber Bearing and Lead Rubber Bearing to transmit horizontal loads from the superstructure to the substructure. As such, the High Damping Rubber Bearing and Lead Rubber Bearing needs to be fixed in the required direction in order to restrain itself from movement. Usually, these horizontal forces are originated from wind load, braking force, centrifugal force on curved elevated span, etc. It should be noted that such approach must be designed cautiously in order not to interfere with the efficiency of the isolation system during seismic movement.

## High Damping Rubber Bearing (HDRB)

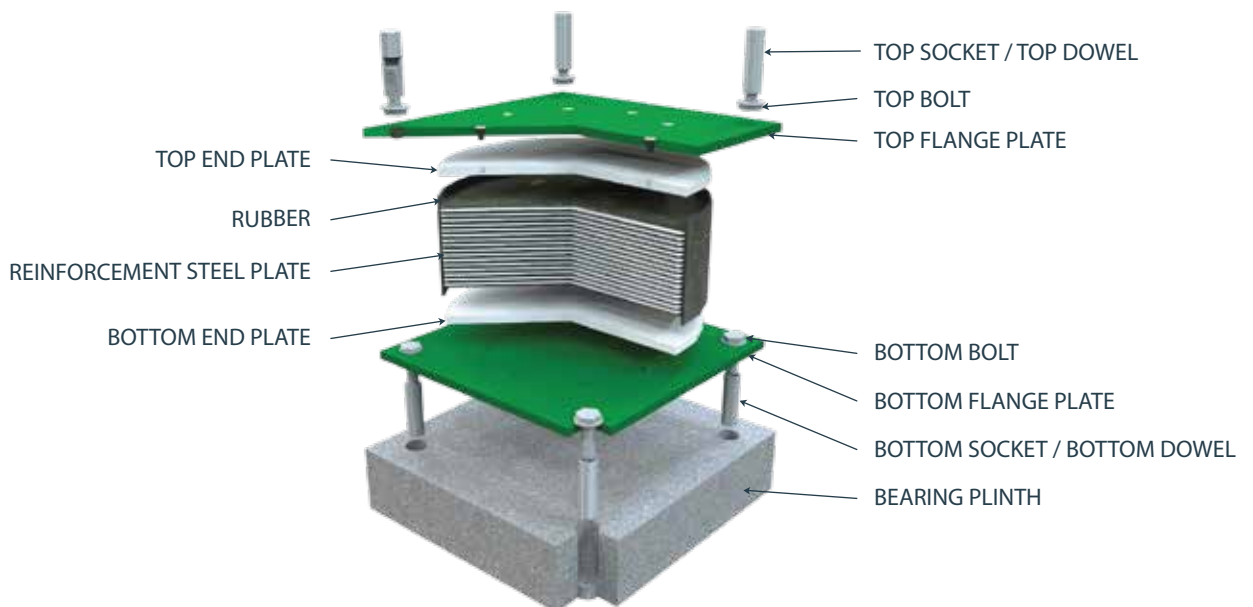

## Lead Rubber Bearing (LRB)

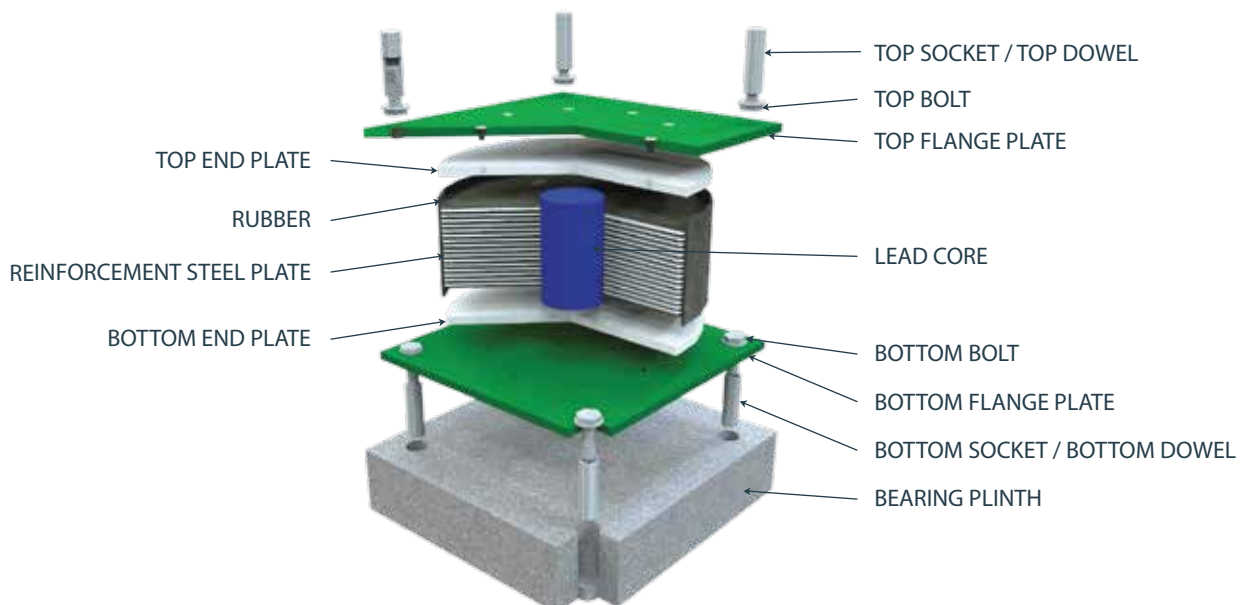

# 10.0 INSTALLATION

## 10.1.1 INSTALLATION - BEARING WITH STEEL

### STEP 1 :

Prepare block out / recess holes using template / PVC pipes and cast the bottom plinth according to the required height and size.

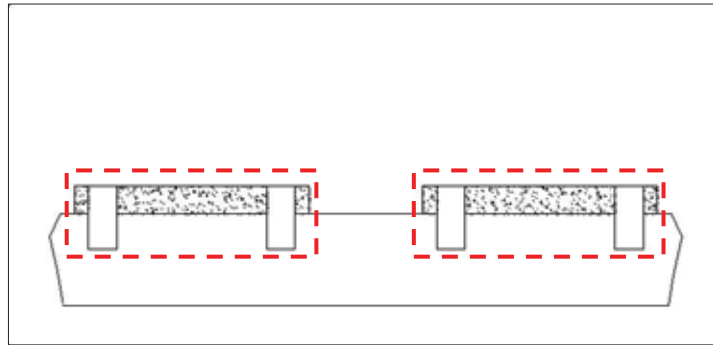

### STEP 2 :

Place the Bearing on the bottom plinth. Use shim plates to ensure bearing reaches the required height. Place the hydraulic jacks / temporary support at designated location.

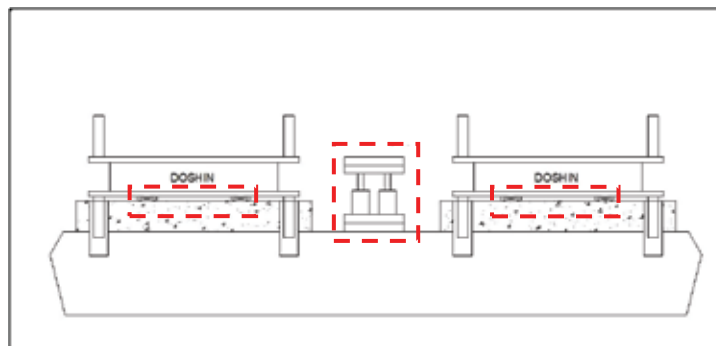

### STEP 3 :

Launch the steel structural above the Bearing.

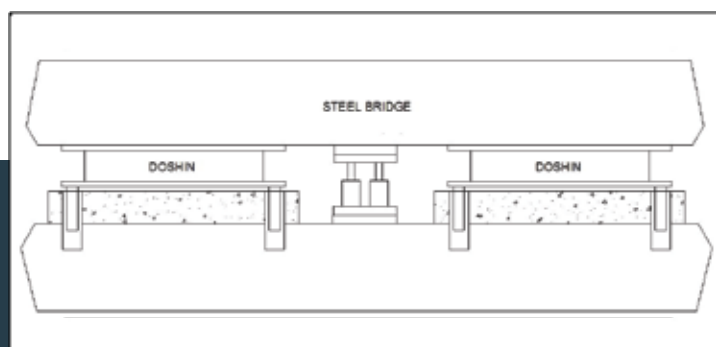

STEP 4 :

Tighten the bolts at the top attachment plate to its respective torque value.

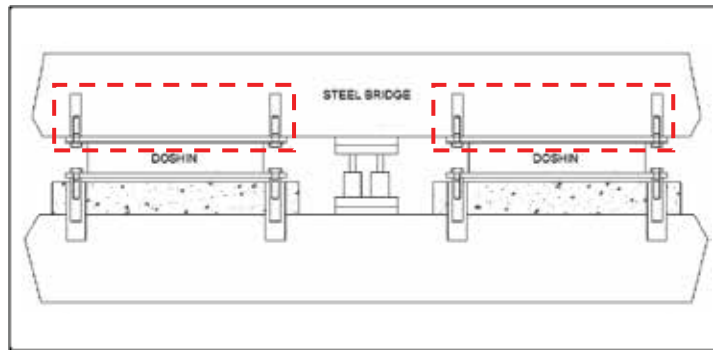

STEP 5 :

Prepare formwork for grouting. Using approved grout material, grout the bottom anchor plate using manual pouring method.

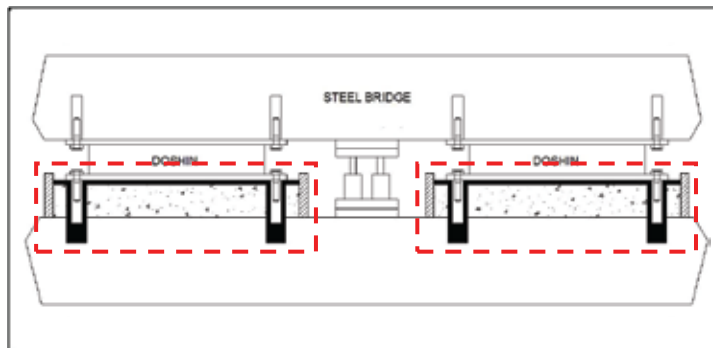

STEP 6 :

Remove the hydraulic jacks / temporary support after the grout has achieved the required strength.

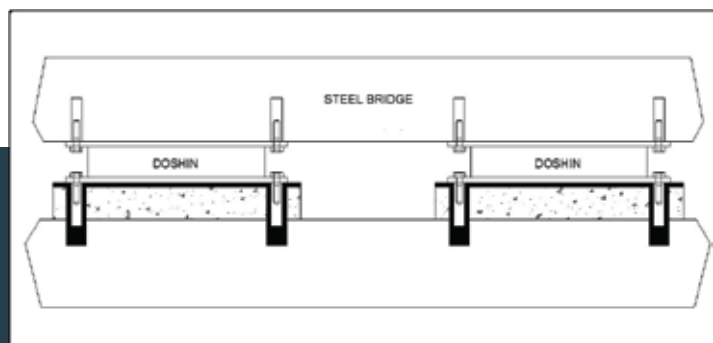

10.1.2 INSTALLATION - BEARING WITH CONCRETE

STEP 1 :

Prepare block out/ recess holes using template / PVC pipe and cast the bottom plinth according to the required height and size.

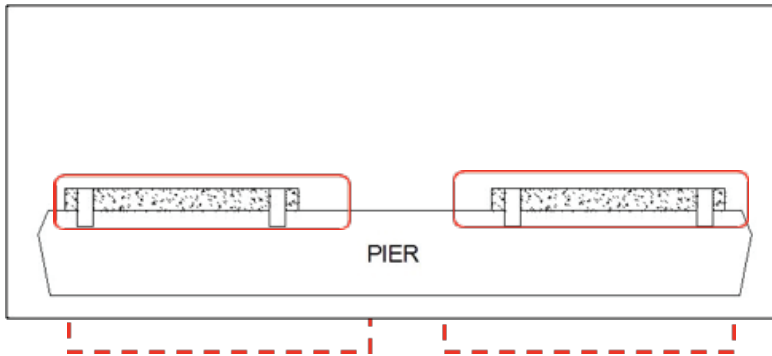

STEP 2 :

Place the Bearing on the bottom plinth. Use shim plates to ensure bearing reaches the required height. Place the hydraulic jacks / temporary support at designated location.

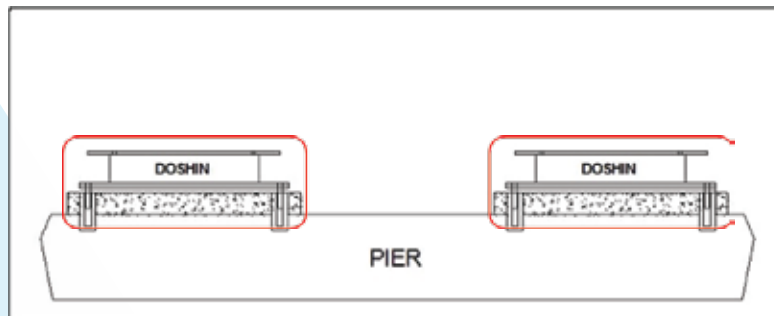

STEP 3 :

Launch the super structural above the Bearing. The hydraulic jacks will absorb the load of the beam first. Gradually decrease the height of the hydraulic jacks until the desired grouting height is achieved. Tighten the bolts at the top and bottom attachments plates to their respective torque values.

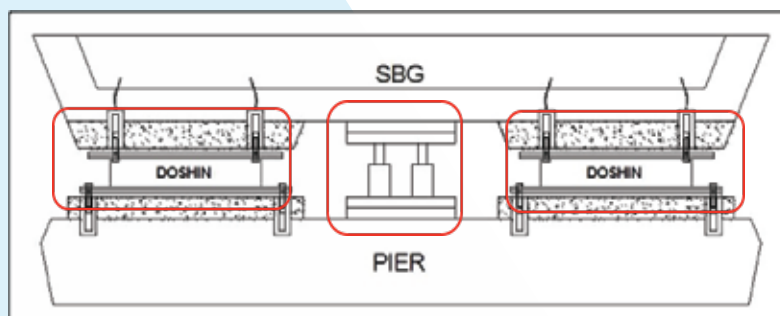



## STEP 4 :

Prepare formwork for grouting. Pour the grout at the bottom plinth and top plinth through the grouting hose.

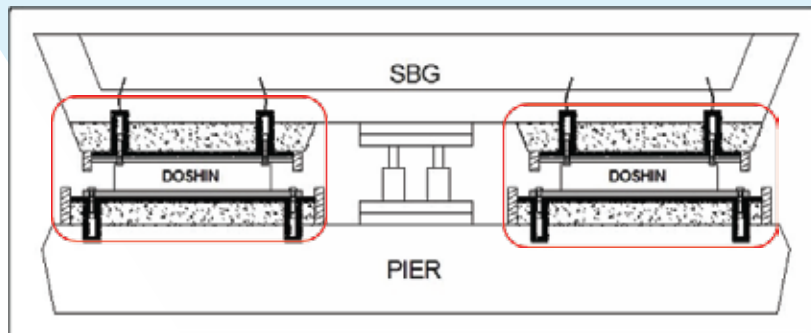

## STEP 5 :

Remove the hydraulic jacks after the grouting plinth has achieved the required strength.

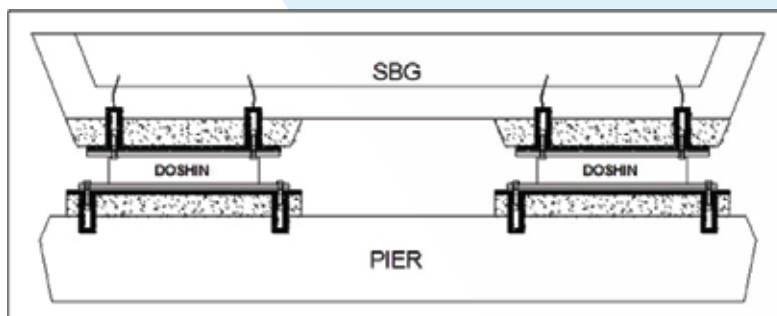

# 10.2 CONNECTION METHODS

## 10.2 CONNECTION METHODS WITH DIFFERENT STRUCTURAL

### 10.2.1 Concrete

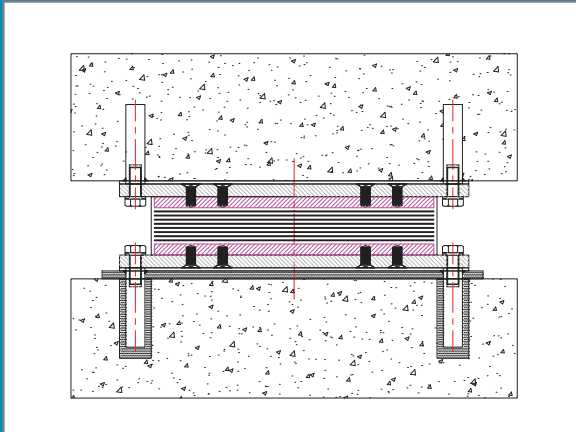

### 10.2.2 Steel / Concrete

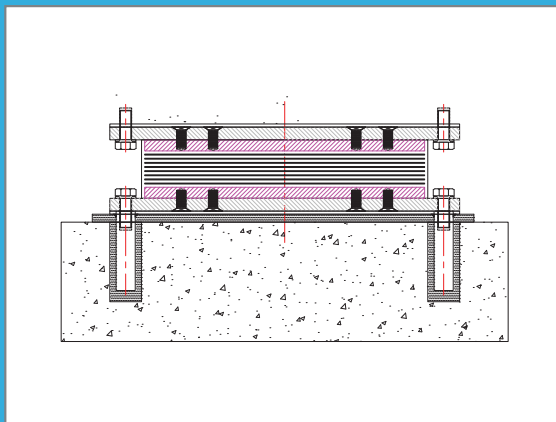

### 10.2.3 Steel

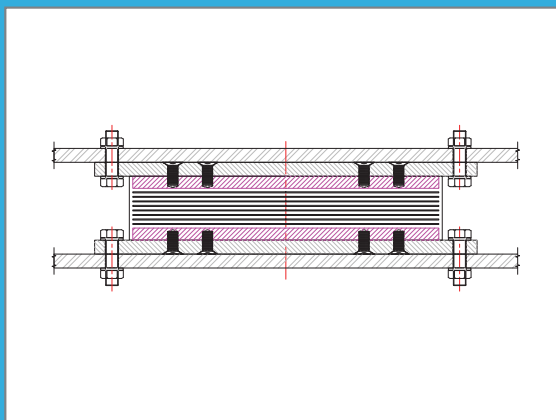

# 11.1 PROJECT REFERENCE

## HIGH DAMPING RUBBER BEARING



KVMRT, SSP Line  
MALAYSIA



LRT 3  
MALAYSIA





# Hospital Claudio Vicuna

CHILE



# Hospital Del Salvador

CHILE



# Penang Second Bridge

MALAYSIA





# University Hospital (UI) INDONESIA



# Wika Tower INDONESIA

INDONESIA



# Cable Stayed Bridge VIETNAM

VIETNAM



# 11.2 PROJECT REFERENCE LEAD RUBBER BEARING

HOSPITAL LAS HIGUERAS  
CHILE

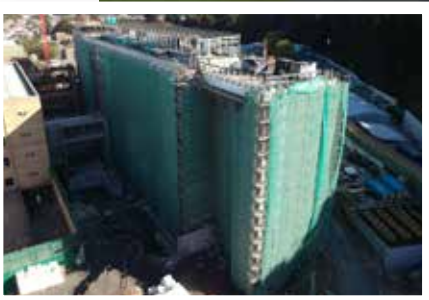



UNIVERSIDAD DE LOS ANDES  
COLOMBIA

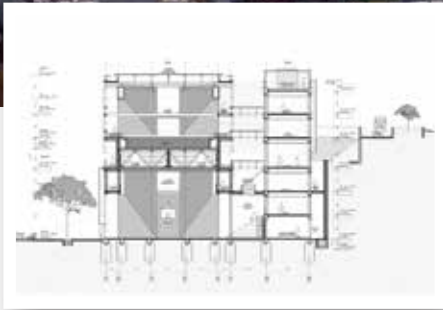
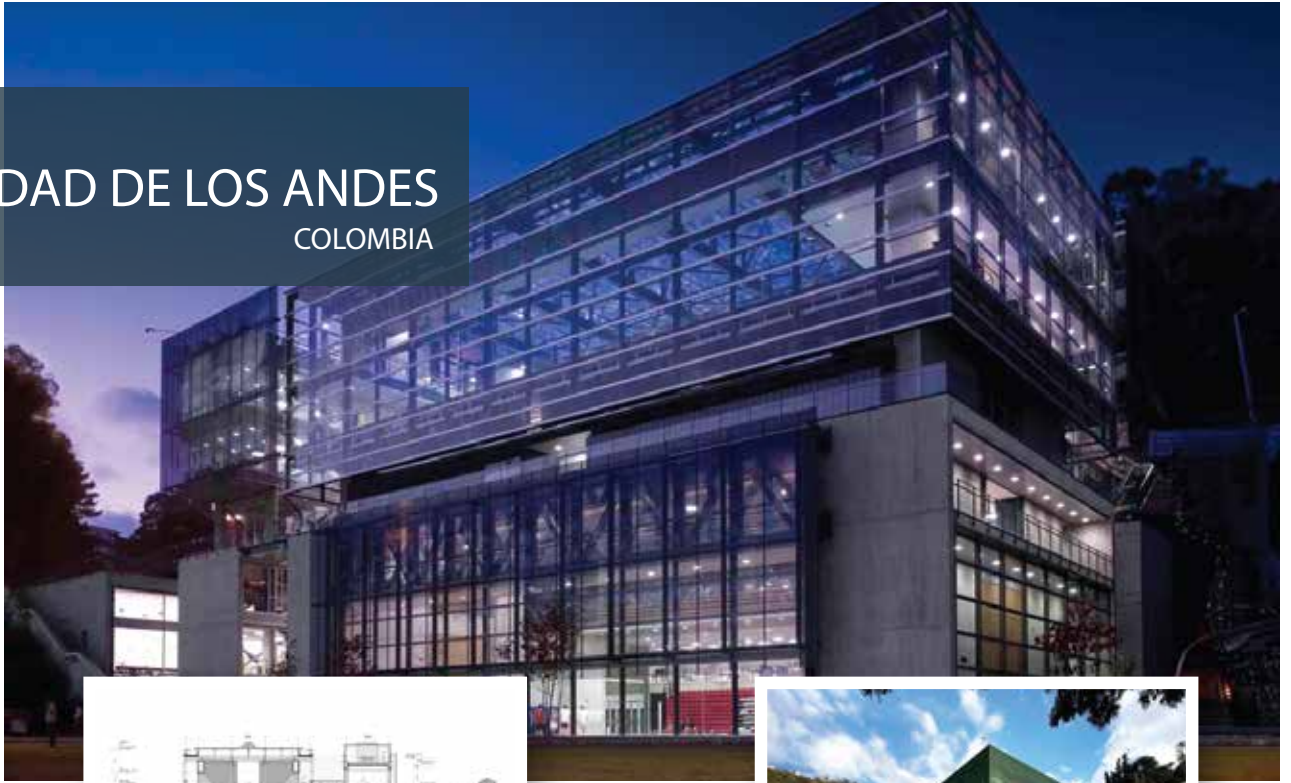

SALAVERRY PORT

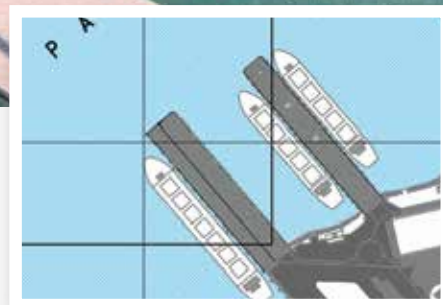



Doshin Rubber Engineering



[doshin@kossan.com.my](mailto:doshin@kossan.com.my)



Doshin Rubber Engineering



[www.doshinrubber.com](http://www.doshinrubber.com)



+ 6 03 - 3290 5619 ; + 6 03 - 3290 5621 ; + 6 03 - 3290 5631



Lot PT 34252, Jalan Sekolah, Rantau Panjang, 42100 Klang. Selangor.  
Darul Ehsan. Malaysia.

 **DOSHIN**<sup>®</sup>  
RUBBER ENGINEERING